

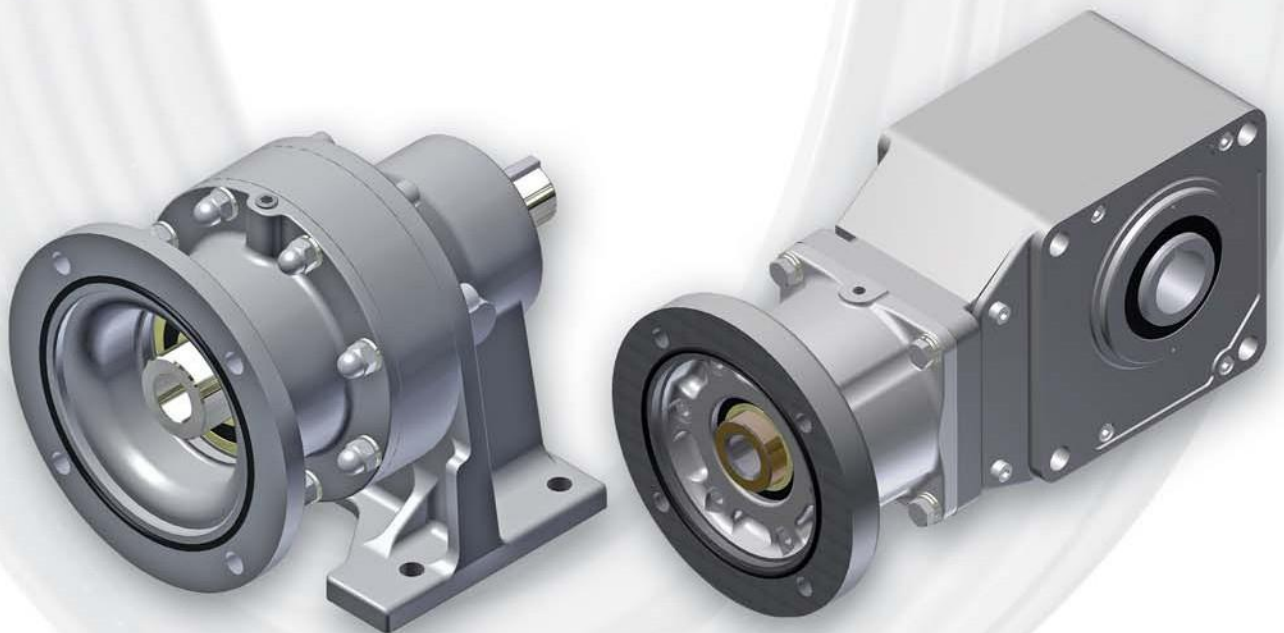

Sumitomo Drive Technologies
Always on the Move

DRIVEN FOR PURITY



DRIVEN FOR PURITY

Here's food for thought: according to the Bureau of Census Annual Survey of Manufacturers, 57% of a company's sales dollar is spent on materials and capital equipment. Choosing the right equipment is more important than ever, especially in food and beverage processing. An equipment failure is a problem; contamination is a catastrophe. Food processing equipment standards of design and production are more stringent every day and specify today's aggressive high-pressure washdown requirements.

Sumitomo Drive Technologies' Cyclo® and Hyponic® food-grade drives feature a unique rotating, multi-lipped seal that protects drives and keeps food safe. Their fully enclosed construction stands up to aggressive cleaning, including high pressure washing. Food-grade lubricants and severe-duty antimicrobial food-grade powder coating provide additional levels of safety. And like all Sumitomo drives, the food-grade products are built to last, giving you the lowest possible life-cycle cost and the highest level of process purity.

Cyclo® Quill Reducer



Hyponic® Quill Reducer



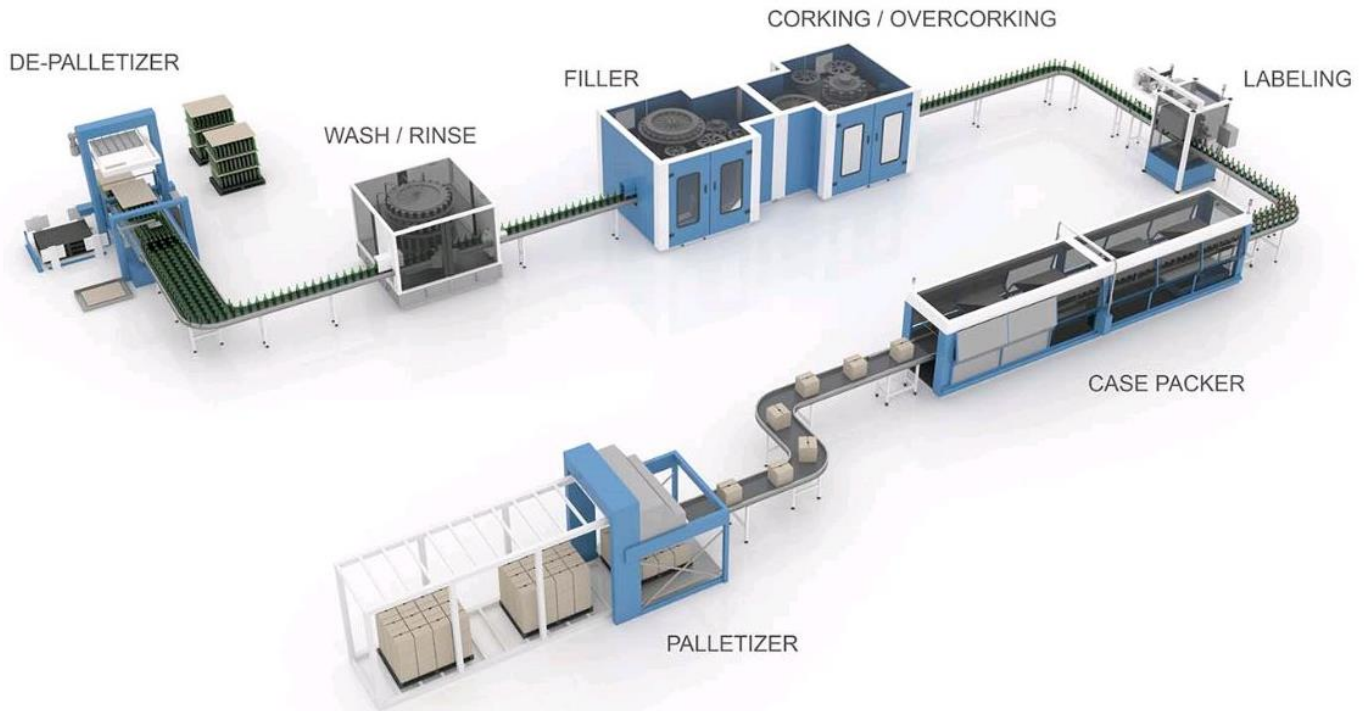

BEVERAGE MANUFACTURING

Beverage manufacturing is highly competitive so efficiency matters. Sumitomo Drive Technologies products provide a solution to the tough demands of Beverage processing applications. The grease lubricated, no maintenance, easy to clean products, provide peace of mind and the knowledge that your process will continue to operate at peak performance.

Applications















Agitators	Cyclo 6000	Cyclo BBB	Cyclo HBB
Batching Equipment	Cyclo 6000	Hyponic	
Blender	Cyclo 6000		
Conveyors	Hyponic	Cyclo 6000	Cyclo BBB
Chiller	Cyclo 6000	Cyclo BBB	
Overhead Doors	Hyponic	Cyclo 6000	Altax
Filler Equipment	Hyponic	Cyclo 6000	IB Precision Gearhead
Industrial Robot	Fine Cyclo	IBPrecisionGearhead	
Loader/Unloader	Cyclo 6000	Cyclo BBB	
Mixing Drum/Mixer	Cyclo BBB	Cyclo 6000	
Palletizer	Cyclo 6000	Servo 6000	IB Precision Gearhead
Packaging Equipment	Hyponic	Cyclo 6000	Astero
Pumps	Paramax 9000	Beier Variator	
Shrink Wrapping	IBPrecisionGearhead	Servo 6000	Astero
Wastewater Treatment	Cyclo BBB	Cyclo 6000	Paramax 9000



Sumitomo Drive Technologies has a proven track record for manufacturing the most dependable, efficient and long-lasting gear drives available today. We now bring that same reliability - and safety - into the food and beverage industry to meet your needs.

To find out more, contact Sumitomo Drive Technologies or your authorized Sumitomo distributor today.

SUMITOMO SPEED REDUCERS FOR FOOD PROCESSING

INLINE	RIGHT ANGLE	OFFSET PARALLEL	PRECISION	LARGE INDUSTRIAL
 <p>Power: 1/8 to 235 HP Ratio: 3:1 to 1,000,000:1 CYCLO® 6000</p>	 <p>Power: 1/8 to 40 HP Ratio: 11:1 to 26,000:1 + CYCLO® BBB</p>	 <p>Power: 1/8 to 40 HP Ratio: 11:1 to 26,000:1 + CYCLO® HBB</p>	 <p>Power: 114 to 4159 lb-in Ratio: 6:1 to 87:1 SERVO 6000</p>	
 <p>Power: 1/8 to 235 HP Ratio: 3:1 to 1,000,000:1 CYCLO® OVERHEAD DRIVE</p>	 <p>Power: 1/8 to 15 HP Ratio: 5:1 to 1,440:1 HYPONIC®</p>	 <p>Power: 1/4 to 300 HP Ratio: 5:1 to 25:1 HSM</p>	 <p>Torque: 115 to 1124 lb-in Ratio: 5:1 to 45:1 IB PRECISION GEARHEAD</p>	 <p>Torque: 23,000 to 5,000,000 lb-in Ratio: 6.3:1 to 500:1 PARAMAX® 9000</p>
 <p>Power: 40 to 90 Watts Ratio: 6:1 to 51:1 ALTAX®</p>	 <p>Torque: 5.75 to 260.47 lb-in Ratio: 5:1 to 240:1 ASTERO®</p>		 <p>Torque: 1318 to 54,339 lb-in Ratio: 29:1 to 179:1 FINE CYCLO®</p>	
 <p>Torque: 1.15 to 173.47 lb-in Ratio: 3:1 to 200:1 ASTERO®</p>				

Bay Engineers Supplies

107 Hull Road, Mount Maunganui 3116

Phone: 0800 229 364

Email: PTorders@bayeng.co.nz

www.bayengineerssupplies.co.nz